

godwin
pumps®

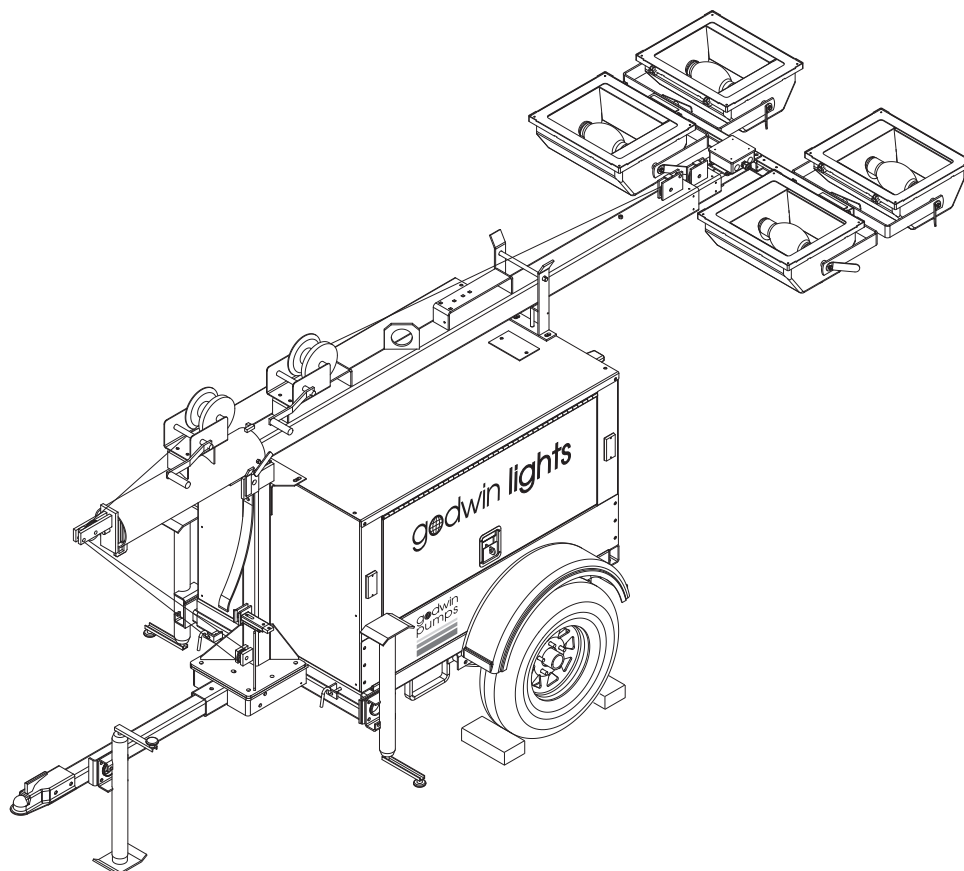

LIGHT TOWER
GLT416 • GLT418



OPERATING MANUAL

INTRODUCTION

This manual provides information and procedures to safely operate and maintain the engine and generator. For your own safety and protection from physical injury, carefully read, understand, and observe the safety instructions described in this manual. *The information contained in this manual was based on machines in production at the time of publication. GODWIN PUMPS OF AMERICA reserves the right to change any portion of this information without notice.*

DO NOT MODIFY or use this equipment for any application other than which it was designed for.

GODWIN PUMPS OF AMERICA recommends that a trained and licensed professional perform all electrical wiring and testing functions. Any wiring should be in compliance with the United States National Electric Code (NEC), state and local codes and Occupational Safety and Health Association (OSHA) guidelines.

Keep a copy of this manual with the unit at all times. Additional copies are available from GODWIN PUMPS OF AMERICA. An engine operator's manual was also supplied with the unit at the time of shipment from the factory. The manual provides detailed operation and maintenance procedures for the engine. Additional copies of the engine operators manual are available from the engine manufacturer.

**GODWIN PUMPS
One Floodgate Road
Bridgeport, NJ 08014**

**Phone: 856-467-3636
FAX: 856-467-4841**

www.godwinpumps.com

Engine Make: _____

Engine Serial Number: _____

Engine Model Number: _____

Generator Make: _____

Generator Model Number: _____

Generator Serial Number: _____

Unit Model Number: _____

Unit Serial Number: _____

▲ WARNING

CALIFORNIA PROPOSITION 65 WARNING: Diesel engine exhaust and some of its constituents are known to the state of California to cause cancer, birth defects and other reproductive harm.

TABLE OF CONTENTS

	Page
INTRODUCTION	2
TABLE OF CONTENTS	3
SAFETY NOTES	4
OPERATING SAFETY	4 - 5
ENGINE SAFETY	5
SERVICE SAFETY	5 - 6
TOWING SAFETY	6
REPORTING TRAILER SAFETY DEFECTS	6
UNIT SERIAL NUMBER LOCATIONS	7
SAFETY SYMBOL SUMMARY	7
SPECIFICATIONS	8 - 9
LIGHT TOWER SET UP	10
RAISING THE TOWER	11
RAISING THE TOWER WITH THE OPTIONAL ELECTRIC WINCH	12
MAIN CONTROL PANEL COMPONENTS - GLT416	13
MAIN CONTROL PANEL COMPONENTS - GLT418	14
ENGINE STARTING AND OPERATION	15
AUTOMATIC SHUTDOWN	16
LIGHT OPERATION	16
AUXILIARY OUTLETS	16
DERATING FOR ALTITUDE	17
SHUTTING DOWN	17
LOWERING THE TOWER	17
LOWERING THE TOWER EQUIPPED WITH THE OPTIONAL ELECTRIC WINCH	17 - 18
REMOVING THE LIGHTS FOR TRANSPORTATION	18
TOWING THE TRAILER	18 - 19
LIFTING THE TRAILER	19
DAILY INSPECTION	19
PERIODIC OR PREVENTIVE MAINTENANCE	20
OPTIONAL LOWER RADIATOR HOSE HEATER USE AND MAINTENANCE	20
TROUBLESHOOTING THE LIGHTS	21
AC WIRING DIAGRAM - GLT416	22
AC WIRING DIAGRAM - GLT418	23
DC WIRING DIAGRAM - MITSUBISHI	24
DC WIRING DIAGRAM - KUBOTA	25
DC CIRCUIT WIRING DIAGRAM - DUAL ELECTRIC WINCH	26
MAST JUNCTION BOX WIRING	27

SAFETY NOTES



This is the safety alert symbol. It is used to alert you to potential personal injury hazards. Obey all safety messages that follow this symbol to avoid possible injury or death.

This manual contains DANGERS, WARNINGS, CAUTIONS, NOTICES and NOTES which must be followed to prevent the possibility of improper service, damage to the equipment, personal injury or death. The following formatting options will apply when calling the readers attention to the DANGERS, WARNINGS, CAUTIONS, NOTICES and NOTES.

▲ DANGER

INDICATES A HAZARDOUS SITUATION WHICH, IF NOT AVOIDED, WILL RESULT IN DEATH OR SERIOUS INJURY.

▲ WARNING

Indicates a hazardous situation which, if not avoided, could result in death or serious injury.

▲ CAUTION

Indicates a hazardous situation which, if not avoided, may result in minor or moderate injury.

NOTICE

Indicates a hazardous situation which, if not avoided, may result in property or equipment damage.

***Note:** Notes contain additional information important to a procedure and will be found within the regular text body of this manual.*

OPERATING SAFETY



Before using the light tower be sure you read and understand all of the instructions! This equipment was designed for specific applications; DO NOT modify or use this equipment for any application other than which it was designed for. Equipment operated improperly or by untrained personnel can be dangerous! Read the operating instructions and familiarize yourself with the location and proper use of all instruments and controls. Inexperienced operators should receive instruction from someone familiar with the equipment before being allowed to operate or set up the light tower. The following points should be practiced at all times:

- The area immediately surrounding the light tower should be dry, clean, and free of debris.
- Position and operate the light tower on a firm, level surface.
- **NEVER** start a unit in need of repair.
- Lower tower when not in use, or if high winds or electrical storms are expected in the area.
- Make certain light tower is well grounded and securely fastened to a good earthen ground.
- The tower extends up to 30 ft. (9m). Make sure area above trailer is open and clear of overhead wires and obstructions.
- Bulbs become extremely hot in use! Allow bulb and light fixture to cool 10-15 minutes before handling.
- Keep area behind trailer clear of people while raising and lowering mast!
- **NEVER** raise, lower or turn mast while unit is operating!
- Trailer must be leveled and outriggers extended before raising tower. Outriggers must remain extended while tower is up.
- If for any reason any part of mast hangs up or winch cable develops slack while raising or lowering tower, STOP immediately! Contact an authorized service representative.
- **NEVER** remove safety pin or pull mast locking pin while tower is up!

- **NEVER** use tower if insulation on electrical cord is cut or worn through.
- **NEVER** operate lights without protective lens cover in place or with a lens cover that is cracked or damaged!

ENGINE SAFETY



Internal combustion engines present special hazards during operation and fueling! Failure to follow the safety guidelines described below could result in severe injury or death. Also read and follow all safety warnings described in the Engine Operator's Manual. A copy of this manual was supplied with unit when it was shipped from the factory.

- **DO NOT** run engine indoors or in an area with poor ventilation unless exhaust hoses are used. Diesel engine exhaust contains carbon monoxide, a deadly, odorless and colorless gas which, if inhaled, can cause nausea, fainting or death. Make sure engine exhaust cannot seep into closed rooms or ventilation equipment.
- **DO NOT** Operate the unit on a combustible surface.
- **DO NOT** fill fuel tank near an open flame, while smoking, or while engine is running. **DO NOT** fill tank in an enclosed area with poor ventilation.
- **DO NOT** operate with the fuel tank cap loose or missing.
- **DO NOT** touch or lean against hot exhaust pipes or engine cylinders.
- **DO NOT** clean air filter with gasoline or other types of low flash point solvents.
- **DO NOT** remove engine coolant cap while engine is hot.
- **DO NOT** operate the unit without a functional exhaust system. Prolonged exposure to sound levels in excess of 85 DBA can cause permanent hearing loss. Wear hearing protection when working around a running engine.
- Keep area around exhaust pipes and air ducts free of debris to reduce the chance of an accidental fire.
- Batteries contain sulfuric acid which can cause severe injury or death. Sulfuric acid can cause eye damage, burn flesh or eat holes in clothing. Protective eye wear and clothing are necessary when working on or around the battery. Always disconnect the NEGATIVE (-) battery cable from the corresponding terminal before performing any service on the engine or other components.
- Shut the engine down if any of the following conditions exist during operation:
 1. Noticeable change in engine speed.
 2. Loss of electrical output.
 3. Equipment connected to the generator overheats.
 4. Sparking occurs.
 5. Engine misfires or there is excessive engine/generator vibration.
 6. Protective covers are loose or missing.
 7. If the ambient air temperature is above 110° F.

SERVICE SAFETY



This unit uses high voltage circuits capable of causing serious injury or death. Only a qualified electrician should troubleshoot or repair electrical problems occurring in this equipment.

- Before servicing light tower, make sure the engine start switch is turned to OFF, circuit breakers are open (off) and the negative terminal on the battery is disconnected. **NEVER** perform even routine service (oil/filter changes, cleaning, etc.) unless all electrical components are shut down.
- **NEVER** allow water to accumulate around the base of the light tower. If water is present, **DO NOT** service!

- **NEVER** service electrical components if clothing or skin is wet. If the unit is stored outside, check the engine and generator for any moisture and dry the unit before use.
- **NEVER** wash the unit with a power washer or high pressure hose.
- Open main circuit breaker before disconnecting battery cables.
- Keep hands, feet, and loose clothing away from moving parts on generator and engine.
- Make sure slings, chains, hooks, ramps, jacks, and other types of lifting devices are attached securely and have enough weight-bearing capacity to lift or hold the equipment safely. Always remain aware of the position of other people around you when lifting the equipment.

TOWING SAFETY



Towing a trailer requires care! Both the trailer and vehicle must be in good condition and securely fastened to each other to reduce the possibility of an accident. Also, some states require that large trailers be registered and licensed. Contact your local Department of Transportation office to check on license requirements for your particular unit.

- Check that the hitch and coupling on the towing vehicle are rated equal to, or greater than, the trailer's "gross vehicle weight rating" (GVWR).
- Check tires on trailer for tread wear, inflation, and condition.
- Inspect the hitch and coupling for wear or damage. **DO NOT** tow trailer using defective parts!
- Make sure the trailer hitch and the coupling are compatible. Make sure the coupling is securely fastened to the vehicle.
- Connect safety chains in a crossing pattern under the tongue and attach the breakaway cable **TO THE REAR BUMPER OF THE TOWING VEHICLE**. Do not attach the cable to the trailer hitch.
- Make sure directional and brake lights on the trailer are connected and working properly.
- Check that all lug nuts holding wheels on are tight and that none are missing.
- Maximum recommended speed for highway towing is 45 m.p.h. Recommended off-road towing speed is not to exceed 10 m.p.h. or less depending on terrain.

When towing, maintain extra space between vehicles and avoid soft shoulders, curbs and sudden lane changes. If you have not pulled a trailer before, practice turning, stopping, and backing up in an area away from heavy traffic.

A film of grease on the coupler will extend coupler life and eliminate squeaking. Wipe the coupler clean and apply fresh grease each time the trailer is towed.

REPORTING TRAILER SAFETY DEFECTS

If you believe your trailer has a defect which could cause a crash or could cause injury or death, you should immediately inform the National Highway Traffic Safety Administration (NHTSA) in addition to notifying GODWIN PUMPS OF AMERICA.

If NHTSA receives similar complaints, it may open an investigation; and if it finds that a safety defect exists in a group of vehicles, it may order a recall and remedy campaign. However, NHTSA cannot become involved in an individual problem between you, your dealer, or GODWIN PUMPS OF AMERICA.

To contact NHTSA, you may either call the Auto Safety Hotline toll-free at 1-888-327-4236 (TTY:1-800-424-9153), go to <http://www.safercar.gov>; or write to:

Administrator
NHTSA
1200 New Jersey Avenue S.E.
Washington, DC 20590

You can also obtain other information about motor vehicle safety from <http://www.safercar.gov>.

UNIT SERIAL NUMBER LOCATIONS

Refer to the illustrated locations to find the unit ID tag, and trailer ID tag on your unit. Important information, such as the unit serial number, model number and Vehicle Identification Number (V.I.N.) for your trailer are found on these tags. Record the information from these tags, so it is available if the tags are lost or damaged. When ordering parts or requesting technical service information, you may be asked to specify this information.

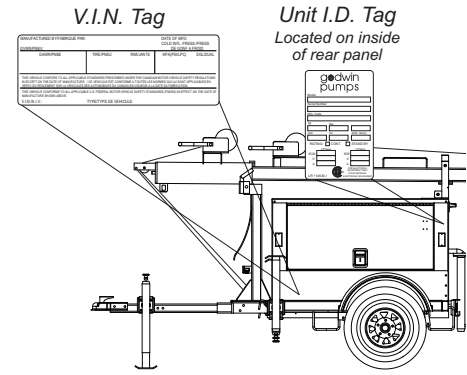

SAFETY SYMBOL SUMMARY

This equipment has been supplied with numerous safety and operating decals. These decals provide important operating instructions and warn of dangers and hazards. Replace any missing or hard-to-read decals and use care when washing or cleaning the unit. Decal placement and part numbers can be found in the parts manual. Below is a summary of the intended meanings for the symbols used on the decals.

	Safety alert symbol; Used to alert you to potential personal injury hazards.		Asphyxiation hazard; Operate in well ventilated area.
	Hot surface(s) nearby.		Dangerous voltage may be present.
	Belt/entanglement hazard; Keep body parts clear of this area.		Anchor/tie down point.
	Fan hazard; Keep body parts clear of this area.		Forklift here only.
	Crush hazard; Keep body parts clear of this area.		Use clean diesel fuel only.
	Ultraviolet radiation hazard; Operate only with lens intact.		Burn/scald hazard; pressurized steam.
	Stop engine before fueling.		Read and understand the supplied operator's manual before operating unit.
	Fire/explosion hazard; Keep open flames away from unit.		Unit electrical ground.
	Lift here only.		

SPECIFICATIONS

Read this manual carefully before attempting to use this light tower. The potential for property damage, personal injury or death exists if this equipment is misused or installed incorrectly. Read all of the manuals included with this unit. Each manual details specific information regarding items such as set up, use and service requirements. SPECIFICATIONS ARE SUBJECT TO CHANGE WITHOUT NOTICE.

MODEL	GLT416	
Engine		
Make/Brand.....	MITSUBISHI.....	KUBOTA
Model.....	L3E-W461ML.....	D1005-E3BG1-MGM-1
Type.....	Diesel, liquid cooled, 4-stroke	Diesel, liquid cooled, 4-stroke
Horsepower - prime hp (kW)	10.5 (7.8).....	11.7 (8.7)
Horsepower - standby hp (kW)	12.2 (9.1).....	13.1 (9.8)
Operating Speed rpm	1800.....	1800
Displacement in ³ (L)	57.97 (0.95).....	61.08 (1.00)
Cylinders - qty	3.....	3
Fuel Consumption - 100% prime gph (Lph)	0.47 (1.78).....	0.50 (1.89)
Battery Type - Group Number.....	24.....	24
Battery Voltage (Quantity per Unit)	12V (1).....	12V (1)
Battery Rating	440 CCA.....	440 CCA
Generator		
Make/Brand.....	Marathon Electric	Marathon Electric
Model.....	201CSA5411	201CSA5411
Type, Insulation.....	Brushless, F	Brushless, F
Generator Set (Engine/Generator)		
Output kW (kVA)	6.0 (6.0).....	6.0 (6.0)
Output Voltage V	120/240, single phase	120/240, single phase
Output Amperes 120V (240V) A	50 (25).....	50 (25)
Frequency Hz	60.....	60
Power Factor.....	1 (1Ø).....	1 (1Ø)
Weights		
Dry Weight lbs (kg)	1640 (744).....	1657 (752)
Operating Weight lbs (kg)	1853 (841).....	1870 (848)
Capacities		
Fuel Tank Volume gal (L)	30 (114).....	30 (114)
Usable Fuel Volume gal (L)	30 (114).....	30 (114)
Coolant (incl. engine) qt (L)	4.5 (4.3).....	4.8 (4.5)
Oil (incl. filter) qt (L)	3.8 (3.6).....	5.4 (5.1)
Maximum Run Time hrs	64.....	60
AC Distribution		
Circuit Breaker Size	30.....	30
Voltage Regulation.....	Capacitor +/-6%	Capacitor +/-6%
Voltages Available 1Ø.....	120, 240	120, 240
Lighting		
Lighting Type.....	Metal Halide	Metal Halide
Ballast Type	Coil & Core	Coil & Core
Lumens	440,000	440,000
Coverage acres (m2)	5 - 7 (20,234 - 28,328)	5 - 7 (20,234 - 28,328)
Dimensions		
Length w/ mast stowed in (m)	170 (4.32).....	170 (4.32)
Width in (m)	49 (1.25).....	49 (1.25)
Width w/ outriggers extended in (m)	98 (2.49).....	98 (2.49)
Height w/ mast stowed in (m)	68 (1.73).....	68 (1.73)
Maximum height of tower ft (m)	30 (9.14).....	30 (9.14)
Trailer		
Number of Axles	1.....	1
Capacity - Axle Rating lbs (kg)	2200 (998).....	2200 (998)
Tire Size in	13.....	13
Hitch - Standard	2" Ball.....	2" Ball
Maximum Tire Pressure psi	50.....	50

SPECIFICATIONS

Read this manual carefully before attempting to use this light tower. The potential for property damage, personal injury or death exists if this equipment is misused or installed incorrectly. Read all of the manuals included with this unit. Each manual details specific information regarding items such as set up, use and service requirements. SPECIFICATIONS ARE SUBJECT TO CHANGE WITHOUT NOTICE.

MODEL

GLT418

Engine

Make/Brand.....	MITSUBISHI.....	KUBOTA
Model	L3E-W461ML	D1105-E3BG
Type	Diesel, liquid cooled, 4-stroke	Diesel, liquid cooled, 4-stroke
Horsepower - prime hp (kW)	10.5 (7.8).....	13.5 (10.1)
Horsepower - standby hp (kW)	12.2 (9.1).....	15.4 (11.5)
Operating Speed rpm	1800	1800
Displacement in ³ (L)	57.97 (0.95).....	68.53 (1.12)
Cylinders - qty	3	3
Fuel Consumption - 100% prime gph (Lph)	0.63 (2.38).....	0.70
Battery Type - Group Number	24	24
Battery Voltage (Quantity per Unit)	12V (1)	12V
Battery Rating	440 CCA.....	440 CCA

Generator

Make/Brand.....	Marathon Electric	Marathon Electric
Model	201CSA5412	201CSA5412
Type, Insulation	Brushless, F	Brushless, F

Generator Set (Engine/Generator)

Output kW (kVA)	7.3 (7.3).....	8.0 (8.0)
Output Voltage V	120/240, single phase	120/240, single phase
Output Amperes 120V (240V) A	61 (30).....	66 (33)
Frequency Hz	60	60
Power Factor.....	1 (1Ø).....	1 (1Ø)

Weights

Dry Weight lbs (kg)	1662 (754).....	1679 (762)
Operating Weight lbs (kg)	1875 (850).....	1892 (859)

Capacities

Fuel Tank Volume gal (L)	30 (114).....	30 (114)
Usable Fuel Volume gal (L)	30 (114).....	30 (114)
Coolant (incl. engine) qt (L)	4.5 (4.3).....	4.8 (4.5)
Oil (incl. filter) qt (L)	3.8 (3.6).....	5.4 (5.1)
Maximum Run Time hrs	48	43

AC Distribution

Circuit Breaker Size	40	40
Voltage Regulation	Capacitor +/-6%	Capacitor +/-6%
Voltages Available 1Ø.....	120, 240	120, 240

Lighting

Lighting Type.....	Metal Halide	Metal Halide
Ballast Type	Coil & Core.....	Coil & Core
Lumens	440,000	440,000
Coverage acres (m²)	5 - 7 (20,234 - 28,328).....	5 - 7 (20,234 - 28,328)

Dimensions

Length w/ mast stowed in (m)	170 (4.32).....	170 (4.32)
Width in (m)	49 (1.25).....	49 (1.25)
Width w/ outriggers extended in (m)	98 (2.49).....	98 (2.49)
Height w/ mast stowed in (m)	68 (1.73).....	68 (1.73)
Maximum height of tower ft (m)	30 (9.14).....	30 (9.14)

Trailer

Number of Axles	1	1
Capacity - Axle Rating lbs (kg)	2200 (998).....	2200 (998)
Tire Size in	13	13
Hitch - Standard	2" Ball.....	2" Ball
Maximum Tire Pressure psi	50	50

LIGHT TOWER SET UP

1. For maximum light coverage locate tower at ground level or in a spot higher than the area being illuminated by the lamps.

▲ WARNING

The tower extends up to 30 ft. (9.14 m). Make sure area above the trailer is open and clear of overhead wires and obstructions.

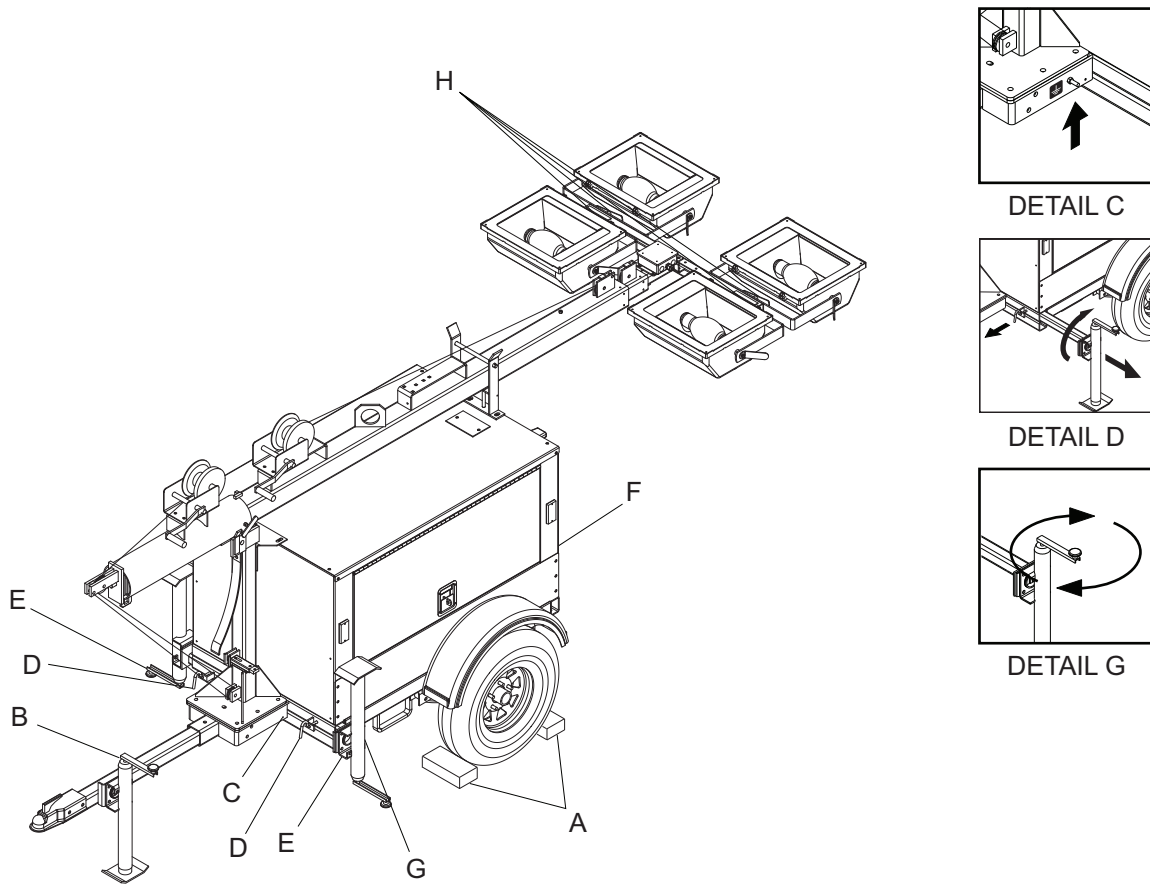

2. Place the trailer on firm ground that is relatively flat. This will make it easier to level the tower. Block the wheels on the trailer to keep it from moving (A).
3. Pull the locking pin on the tongue jack and rotate it 90° until the spring loaded pin snaps back into place (B). Turn the jack handle clockwise to raise the trailer tongue off of the towing vehicle.
4. Connect a good earthen ground to the grounding stud on the frame of the trailer near the trailer tongue (C).
5. Pull the locking pins (D) on the outriggers (E) and pull the outriggers out until the spring loaded locking pin snaps back into place. Pull the locking pin on the outrigger jacks and rotate them 90° so the jack pads are facing down and the spring loaded pin snaps back into place.
6. Pull the locking pin on the rear jack (F) and rotate it 90° until the spring loaded pin snaps back into place. Turn the jack handle clockwise to start leveling the trailer. Adjust all four jacks by turning their handles clockwise until they are firmly in contact with the ground and the trailer is as level as possible (G).
7. Before raising the tower it may be necessary to adjust the lamps. The lamps may be adjusted up, down, left or right by loosening the wing nuts on the trunnion (H) and aiming the lamps in the desired direction. Tighten the hardware completely and make sure the lamps are connected to the junction box.

RAISING THE TOWER

▲ WARNING

The trailer must be leveled with the outriggers extended before raising the tower. The outriggers must remain extended while the tower is up. Failure to level the trailer or extend the outriggers will severely reduce the stability of the unit and could allow the tower to tip and fall.

1. Remove the mast cradle locking pin from the mast cradle (I).
2. Check both sets of mast cables for excessive wear or damage. Make sure the cables are properly centered in each pulley (J). Check the electrical cord for damage.

▲ WARNING

Do not start the unit if the insulation on the electrical cord is cut or worn through. Bare wires in contact with the mast or frame may energize the trailer and cause electrocution. Repair or replace cord.

3. Make sure the area behind the unit is clear before raising the mast to the vertical position.
4. Remove the safety pin (K) from the mast lock bar (L). Using the handle for the lower mast winch (M), raise the mast until it is vertical and the tab on the mast is positioned into the mast lock. The mast lock bar should snap into place automatically. Secure the lock with the safety pin (N).
5. After the mast is up and locked into place, use the upper mast winch (O) to telescope the tower to the desired height. Extend the mast slowly, making sure that the electrical cord is extending at the top sections of the mast. If, for any reason, the winch cable begins to develop slack or any of the tower sections get stuck, STOP IMMEDIATELY and contact an authorized service center.

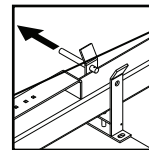

DETAIL I

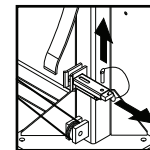

DETAIL K

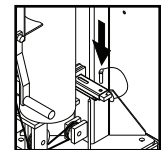

DETAIL N

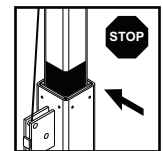

DETAIL P

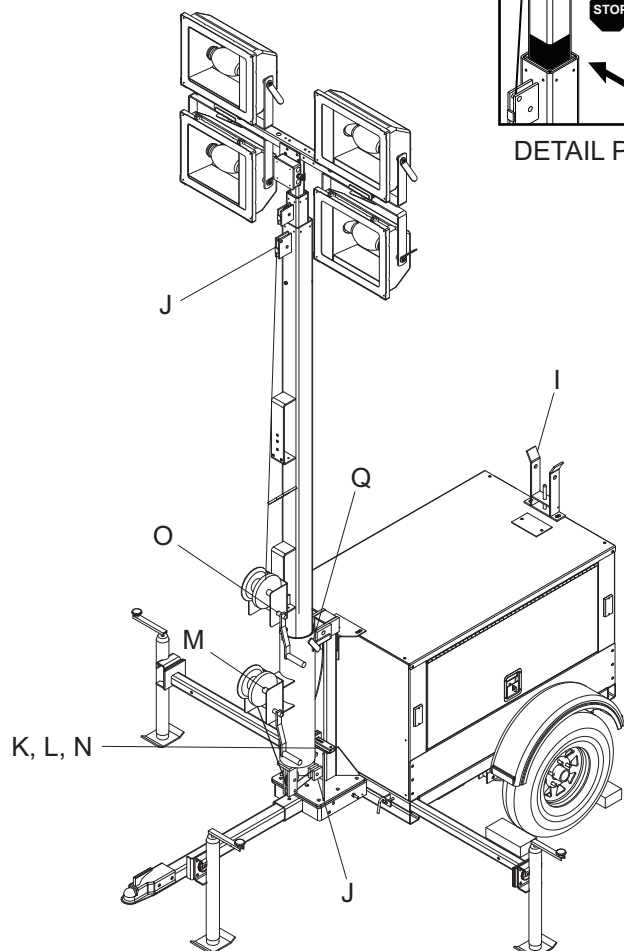

▲ CAUTION

Do not extend the mast beyond the colored mark on the middle mast tube (P).

6. The mast can be rotated by loosening the locking knob at the bottom of the mast (Q). Turn the mast until the lights face in the desired direction and then tighten the knob.

▲ WARNING

Never raise or lower the mast while the unit is operating!
Never remove the safety pin or mast lock while the tower is up.
Releasing the lock will cause the mast to fall.

RAISING THE TOWER WITH THE OPTIONAL ELECTRIC WINCH

1. Set up and level the trailer as described on page 10, and follow steps 1-3 on page 11.
2. Remove the safety pin from the mast lock bar (R).
3. Press the lower winch control toggle switch upward to raise mast into the vertical position (S). Hold switch until the mast lock is engaged. The mast lock bar should snap into place automatically. **Note:** On light towers equipped with the electric winch option, a limit switch on the mast tube will disconnect power to the lower electric winch to prevent deadheading the winch.
4. Secure the lock with the safety pin (T).
5. Press and hold the upper winch control toggle switch upward to telescope the mast to desired height (U). Extend the mast slowly, making sure that the coiled electrical cord is extending at the top sections of the mast. If, for any reason, the winch cable begins to develop slack or any of the tower sections get stuck, STOP IMMEDIATELY and contact an authorized service center.

⚠ CAUTION

Do not extend the mast beyond the colored mark on top of the lower mast section (V). On light towers equipped with the electric winch option, a limit switch on the main mast section will disconnect power to the upper electric winch to prevent over extending the mast.

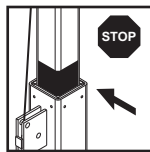

DETAIL V

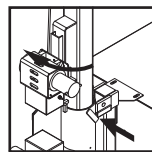

DETAIL W

6. The mast can be rotated by loosening the locking knob at the bottom of the mast (W). Turn the mast until the lights face in the desired direction and then tighten the knob.

⚠ WARNING

Never raise or lower the mast while the unit is operating!
Never remove the safety pin or mast lock while the tower is up.
Releasing the lock will cause the mast to fall.

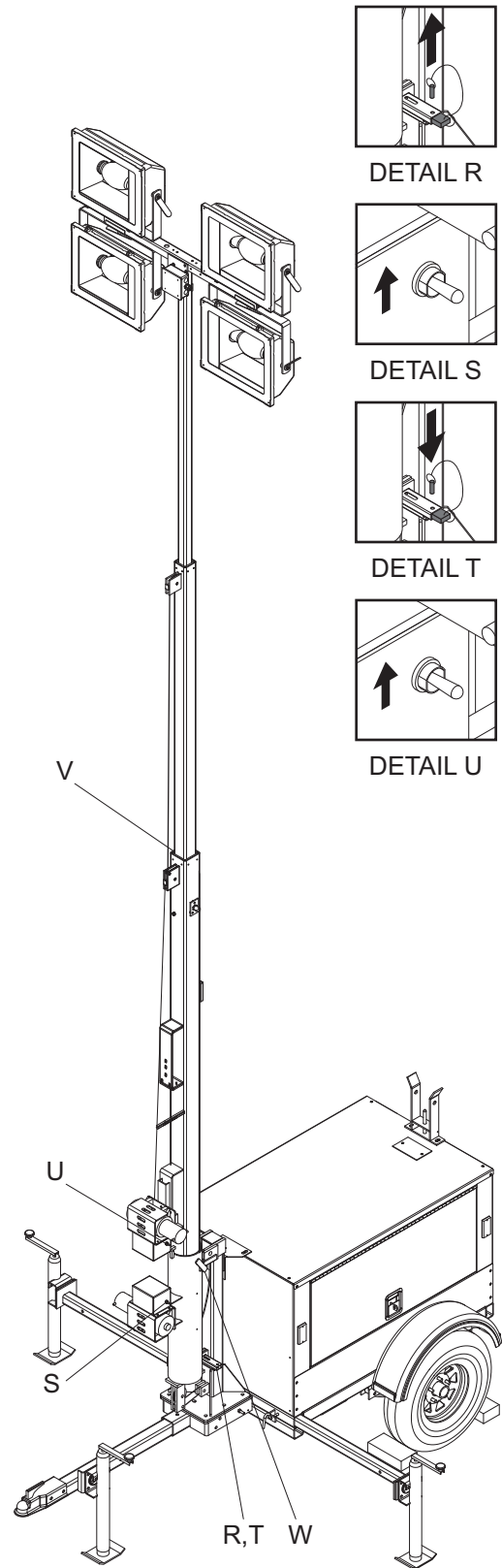

MAIN CONTROL PANEL COMPONENTS - GLT416

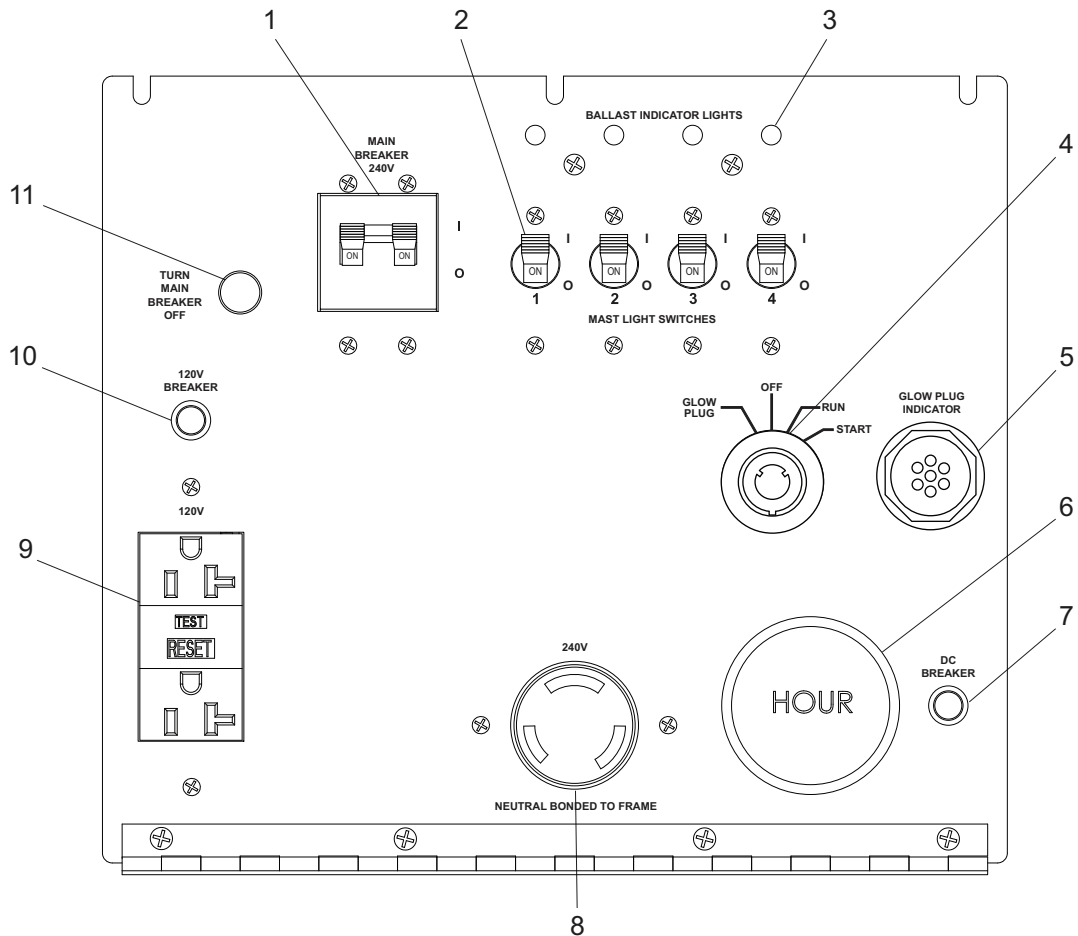

1. **MAIN CIRCUIT BREAKER:** This 240V (30A) breaker will disconnect power to the lights and auxiliary outlets. It will also disable the starting circuit if engine starting is attempted when the main breaker is on.
2. **LIGHT SWITCHES:** One circuit breaker is supplied for each light.
3. **BALLAST INDICATOR LIGHTS:** Indicates power from the ballast to each light.
4. **ENGINE STARTING SWITCH:** Keyed switch operates glow plugs, starts and stops engine.
5. **GLOW PLUG INDICATOR:** Indicates operation of the engine glow plugs (Mitsubishi engines only).
6. **ENGINE HOUR METER:** Keeps track of engine hours for service.
7. **DC BREAKER:** Circuit breaker (10A) for the engine electrical system.
8. **240V TWIST LOCK OUTLET:** This 240V (30A) outlet supplies power for accessories connected to the generator when the engine is running and the main circuit breaker is switched to the ON "I" position.
9. **120V DUPLEX OUTLETS:** This unit is equipped with one 120V (20A) GFCI outlet to supply power for accessories connected to the generator when the engine is running and the main circuit breaker is switched ON ("I").
10. **120V BREAKER:** This 120V (20A) circuit breaker is supplied for the 120V GFCI duplex outlets.
11. **CIRCUIT BREAKER INDICATOR LIGHT:** This light indicates that the main circuit breaker must be opened (switched off) before starting the engine.

MAIN CONTROL PANEL COMPONENTS - GLT418

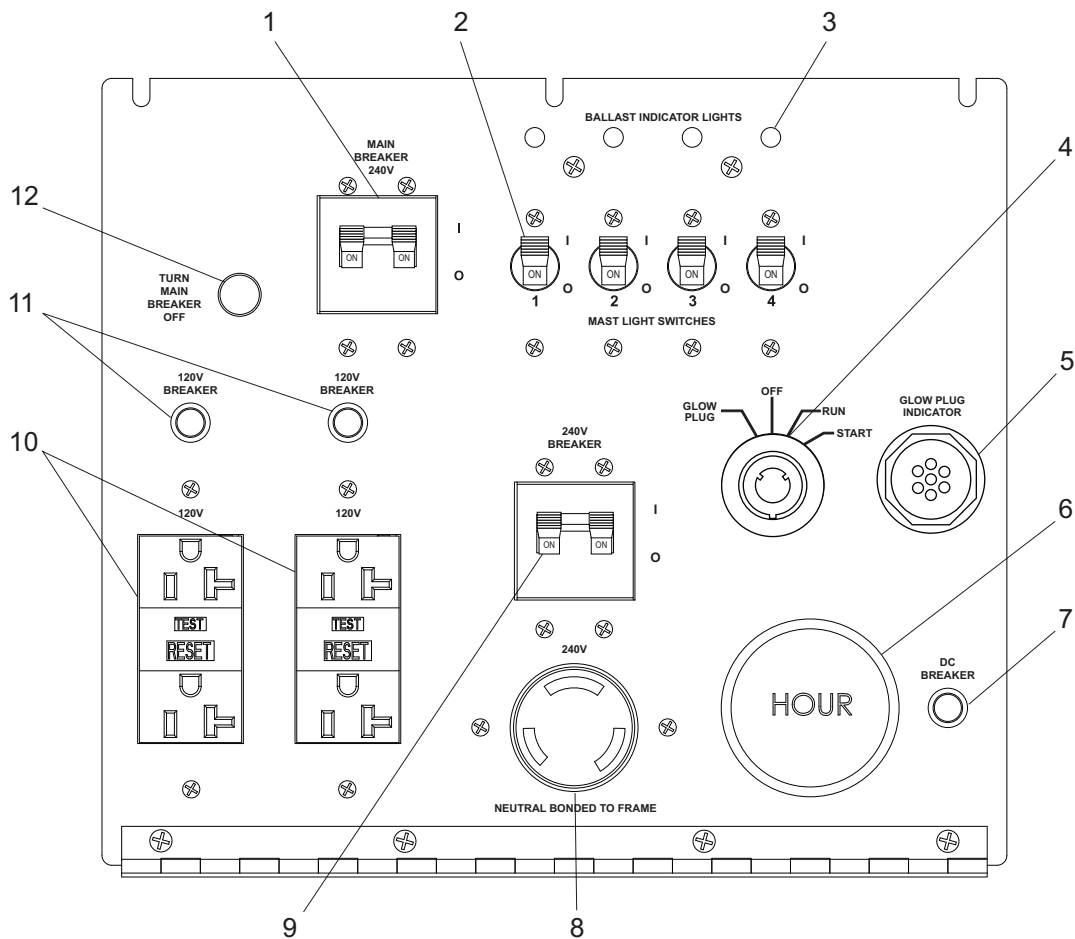

1. **MAIN CIRCUIT BREAKER:** This 240V (40A) breaker will disconnect power to the lights and auxiliary outlets. It will also disable the starting circuit if engine starting is attempted when the main breaker is on.
2. **LIGHT SWITCHES:** One circuit breaker is supplied for each light.
3. **BALLAST INDICATOR LIGHTS:** Indicates power from the ballast to each light.
4. **ENGINE STARTING SWITCH:** Keyed switch operates glow plugs, starts and stops engine.
5. **GLOW PLUG INDICATOR:** Indicates operation of the engine glow plugs (Mitsubishi engines only).
6. **ENGINE HOUR METER:** Keeps track of engine hours for service.
7. **DC BREAKER:** Circuit breaker (10A) for the engine electrical system.
8. **240V TWIST LOCK OUTLET:** This 240V (30A) outlet supplies power for accessories connected to the generator when the engine is running and both the main circuit breaker and 240V breaker are switched to the ON "I" position.
9. **240V BREAKER:** This 240V (30A) circuit breaker is supplied for the 240V twist-lock outlet.
10. **120V DUPLEX OUTLETS:** This unit is equipped with two 120V (20A) GFCI outlets to supply power for accessories connected to the generator when the engine is running and the main circuit breaker is switched ON ("I").
11. **120V BREAKERS:** These 120V (20A) circuit breakers are supplied for the 120V GFCI duplex outlets.
12. **CIRCUIT BREAKER INDICATOR LIGHT:** This light indicates that the main circuit breaker must be opened (switched off) before starting the engine.

ENGINE STARTING AND OPERATION

1. Check engine oil, fuel and coolant levels. **Note:** If the engine was run out of fuel or the fuel tank was drained, it may be necessary to bleed the fuel lines. Refer to the engine operation manual supplied with the unit.
2. Check the condition of the electrical cord on the inside of the unit.

▲ WARNING

Do not start the unit if the insulation on the electrical cord is cut or worn through. Bare wires in contact with the mast or frame may energize the trailer and cause electrocution. Repair or replace cord.

3. Check that the main circuit breaker and individual circuit breakers for each of the lights are in the off "O" position. **Note:** If the red light on the control panel "TURN MAIN BREAKER OFF" is illuminated when the key is turned to the "START" position, the breaker is closed (switched on).

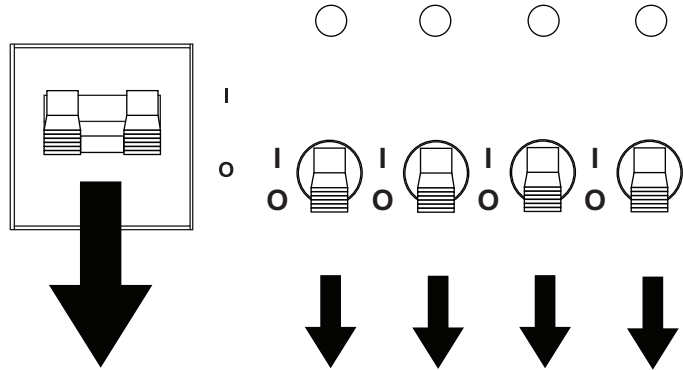

▲ WARNING

NEVER START THE ENGINE WITH ANY OF THE CIRCUIT BREAKERS SWITCHED ON! Any load on the generator during start up will cause severe damage or destroy the generator!

4. Turn the key on the engine start switch to the left GLOW PLUG position and hold the key in place for five seconds, or until the glow plug indicator turns red (there is no glow plug indicator on Kubota units). Turn the key to the right START position and hold it until the engine cranks and starts running. Release the key, it will move to the RUN position. **Note:** For cold weather conditions refer to engine operator's manual for appropriate glow plug interval.

ACTIVATE GLOW PLUGS

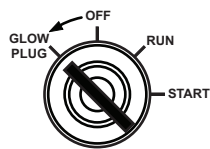

CRANK ENGINE TO START

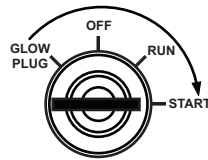

RELEASE KEY

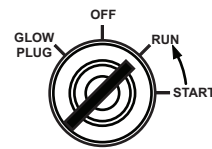

NOTICE

Do not crank the engine longer than 10 seconds at a time. If the engine will not start, wait 30 seconds to allow the starter motor to cool and then repeat the starting procedure. Excessive cranking will cause damage to the starter.

Note: If oil pressure is not obtained within 15 seconds after the key is switched to the "RUN" position, the low-oil automatic shutdown will turn off the fuel supply, stopping the engine. Check the oil level and turn the key to the "OFF" position to reset the oil pressure timer before attempting to restart the engine.

5. Once the engine is running, allow it to reach normal operating temperature before switching on any loads.

AUTOMATIC SHUTDOWN

This unit is equipped with a low oil pressure and high coolant temperature auto-shutdown system. This system will automatically shut off the fuel supply to stop the engine if oil pressure drops too low or the engine exceeds normal operating temperature. Return the switch to the “OFF” position to reset the unit after you have determined the cause of the shutdown.

LIGHT OPERATION

- Once the engine is up to temperature and running smoothly, switch main circuit breaker (1) to the ON “I” position.
- With main circuit breaker on, switch each individual circuit breaker for the lights (2) to ON “I”, one at a time.
- The ballast indicator lights (3) will come on momentarily, then go dark as the lights strike. As the lights warm up, the ballast indicator lights will continue to get brighter and then remain on. This confirms that power is coming from the ballasts to the lights.
- If an indicator light does not come on, the ballast may need to be serviced. If the indicator light comes on and stays lit but the related light is not illuminated, check the bulb or the mast wiring.
- The lights require a warm up period of 5-15 minutes before they reach full output. If the lights are shut down, they require a cool-down period of approximately 10 minutes before they can be switched on again.
- The light tower uses four 1000W bulbs. When checking or replacing the bulbs, wipe them with a clean cloth to avoid leaving any grease, oil residue or fingerprints on the glass. Any residue can create a hot spot on the bulb, causing premature bulb failure.

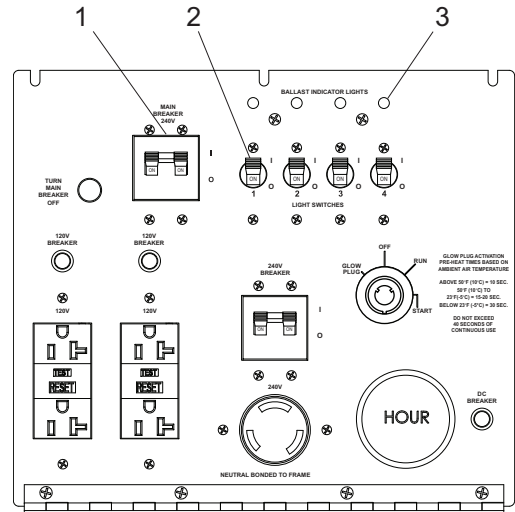

▲ WARNING

NEVER OPERATE THE LIGHTS WITHOUT THE PROTECTIVE LENS COVER OR WITH A LENS COVER THAT IS CRACKED OR DAMAGED! The bulbs in the light fixtures produce high temperatures and operate under pressure. A broken or missing lens cover could cause the bulbs to shatter, causing injury.

▲ WARNING

Bulbs become extremely hot in use! Allow bulb fixture to cool 10-15 minutes before handling.

AUXILIARY OUTLETS

Depending upon the model, the control panel is equipped with two or three outlets for running accessories or tools from the generator. Power is supplied to the outlets any time the engine is running and the main circuit breaker is switched ON “I”. **Note: Do not pull more than 1000W from each outlet when the lights are on. This will overload the generator and cause the main circuit breaker to trip. Should the breaker trip, switch off the lights, remove some of the load to the outlets and wait 10 minutes for the bulbs to cool before turning them back on.**

With all of the lights off, the full generator output may be used with the optional 240V twist-lock outlet.

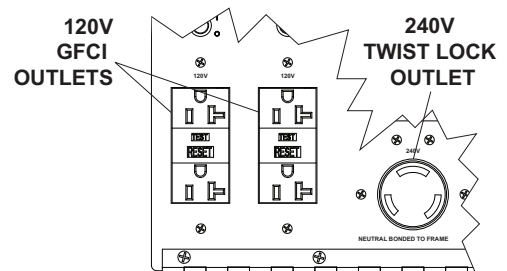

DERATING FOR ALTITUDE

All light towers are subject to derating for altitude and temperature. Although derating should not affect the operation of the lights, it will reduce the available power for operating tools and accessories connected to the auxiliary outlets. Typical reductions in performance are 2-4% for every 1000 ft. (305 m) of elevation and 1% per 10° F (3-5° C) increase in ambient air temperature over 72° F (22.2° C).

SHUTTING DOWN

When you have finished using the light tower proceed with shut down as follows:

1. Remove any loads from the auxiliary outlets.
2. Switch the individual circuit breakers for each light to the OFF "O" position.
3. Switch the main circuit breaker to the OFF "O" position.
4. Turn the ENGINE START SWITCH to the OFF position.

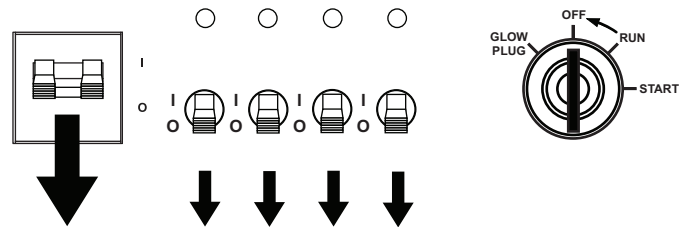

LOWERING THE TOWER

1. Shut down the lights and engine. Allow the lights to cool 10-15 minutes before lowering the tower.
2. Turn the upper mast winch handle to collapse the tower to its lowest position. Make sure the electrical cord returns to the storage tube properly.

▲ WARNING

If the mast hangs up or the winch cable begins to develop slack, STOP IMMEDIATELY! Excess slack in the cable could cause the mast to collapse should it free up without warning. Contact an authorized service center.

3. Loosen the mast rotation knob and rotate the tower so the mast mounted winches are parallel to the front of the unit. The white alignment arrow points should line up on the mast sections and the metal stop tabs should be touching. Tighten the mast rotation knob.
4. Release the mast lock by pulling the safety pin on the mast lock and pulling the lock free. Turn the handle of the lower mast winch until the mast spring begins to pivot the tower down. Release the mast lock and continue to lower the tower until it rests in the cradle. **Note:** *If the mast lock does not pull free, operate the lower winch slightly to relieve pressure on the mast lock.*
5. After the mast is completely down, insert the cradle lock pin and secure it with the safety pin.
6. Position lights to aim at the ground. If the trailer is going to be moved, GODWIN PUMPS OF AMERICA strongly recommends that the lights be removed from the mast and stowed for transportation. See REMOVING THE LIGHTS FOR TRANSPORTATION section on page 18.

LOWERING THE TOWER EQUIPPED WITH THE OPTIONAL ELECTRIC WINCH

1. Shut down the lights and engine. Allow the lights to cool 10-15 minutes before lowering the tower.
2. Loosen the mast rotation knob and rotate the tower so the mast mounted winches are parallel to the front of the unit. The white alignment arrow points should line up on the mast sections and the metal stop tabs should be touching. Tighten the mast rotation knob.

3. Press and hold the upper winch control toggle switch downward to collapse the mast to its lowest level. Make sure the coiled electrical cord on the top sections of the mast does not get tangled on the mast sections. **Note:** *Some electric winch models are equipped with an anti-backlash safety limit switch. This switch will disconnect power to the winch if excess cable slack is detected, preventing accidental lowering of the tower. If, for any reason, the cable begins to develop slack or any of the tower sections get stuck, **STOP IMMEDIATELY** and contact an authorized service center.*
4. Release the mast lock bar by pulling the safety pin on the mast lock and pulling the lock bar free. Lower the mast by holding the lower winch control toggle switch to the right until the mast is resting in the transport cradle. **Note:** *If the lock bar does not pull free, activate lower winch slightly to relieve pressure on the mast lock bar.*
5. After the mast is completely down, insert the cradle lock pin and secure it with the safety pin.
6. Position lights to aim at the ground. If the trailer is going to be moved, GODWIN PUMPS OF AMERICA strongly recommends that the lights be removed from the mast and stowed for transportation.

REMOVING THE LIGHTS FOR TRANSPORTATION

1. On units equipped with quick disconnect fittings for the lights, disconnect the power cords from the junction box at the top of the mast. Replace the dust caps on the junction box. On other units, remove the junction box cover on the top of the mast and disconnect **ONLY** the mast light wires from the terminal blocks. To release the wires from the terminal blocks, flip the locking levers down and pull out the appropriate wires.
2. Remove the lights by removing the wing nut that holds the light fixture bracket to the cross tube. Attach the lights to the storage brackets (if equipped) located on the mast tube on either side of the central lifting eye.

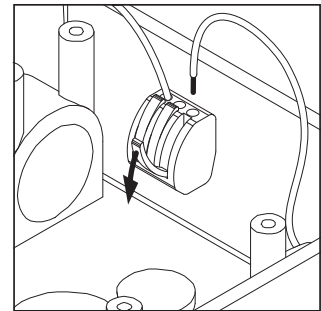

TOWING THE TRAILER

Once the engine is shut down and the mast and lights are properly stowed, the trailer can be made ready for transport.

1. Raise the rear jack completely and release the locking pin to rotate it up into the travel position. Make sure the locking pin snaps into place.
2. Raise the outrigger jacks completely and release the jack locking pin to swing the jacks up into the travel position. Make sure the locking pins snap into place. Release the outrigger locking pins and slide the outriggers into the trailer frame until the locking pins snap into place.
3. Use the drawbar jack to raise or lower the trailer onto the hitch of the towing vehicle. Lock the hitch coupling and attach the safety chains or cables to the vehicle. Release the jack locking pin and rotate the jack into the travel position. Make sure the locking pin snaps into place.
4. To ensure proper operation of the jacks, lube the grease fittings located on the leveling jacks (refer to page 20 for service intervals).
5. Connect any trailer wiring to the tow vehicle. Check for proper operation of the stop and signal lights.
6. Make sure the cradle locking pin is in place.
7. Make sure the doors are properly latched.
8. If the trailer is going to be driven over rough ground, remove the bulbs from the light fixtures.
9. Check for proper inflation of the trailer tires. The maximum tire inflation is 50 psi.
10. Attach a red flag to the end of the mast before towing.

- Maximum recommended speed for highway towing is 45 mph. Recommended off-road towing speed is not to exceed 10 mph or less depending on terrain.

LIFTING THE TRAILER

When lifting the light tower and trailer, attach any slings, chains or hooks directly to the central lifting eye. The lifting eye is located on the mast between the two forklift pockets.

- Make sure the equipment being used to lift the light tower has sufficient capacity. **Note:** See the unit specifications beginning on page 8 for approximate weights.
- Make sure the cradle locking pin is in place.
- Always remain aware of the position of other people and objects around you as you move the unit.
- Use the upper or lower forklift pockets with care. Approach the unit as perpendicular as possible to avoid any damage to the unit. Make sure the mast winch handles or any other obstructions are clear of the forklift tines before lifting.

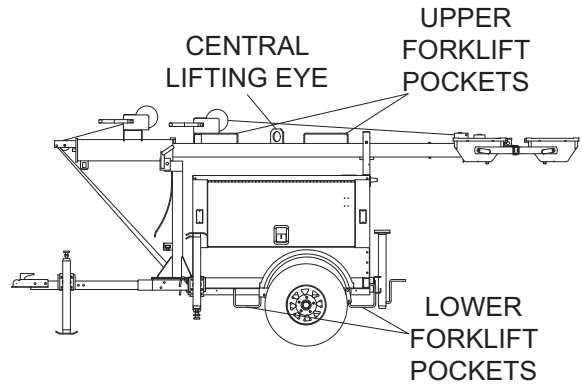

DAILY INSPECTION

- Inspect condition of electrical cords. **DO NOT** use light tower if insulation is cut or worn through.
- Check that winch cables are in good condition and that they are centered on each pulley. **DO NOT** use a cable that is kinked or starting to unravel.

PROPER MAST CABLE ROUTING

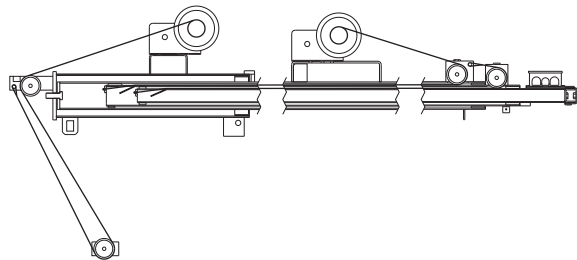

- Check that the safety pins for the mast lock rod and mast lock bar are present and secured with a chain. Check that the spring located in the mast lock bar is not broken or missing. Check the operation of the mast lock bar.
- Check the fuel, oil and coolant levels.
- Check the wheel lugs. Tighten or replace any that are loose or missing. If a tire has been removed for axle service or replaced, tighten the lugs in the order shown, to the following specifications:
 - Start all lug nuts by hand.
 - First pass tighten to 20-25 Ft-Lbs (27-33 Nm).
 - Second pass tighten to 50-60 Ft-Lbs (67-81 Nm).
 - Third pass tighten to 90-120 Ft-Lbs (122-162 Nm).

After the first road use, retorque the lug nuts in sequence.

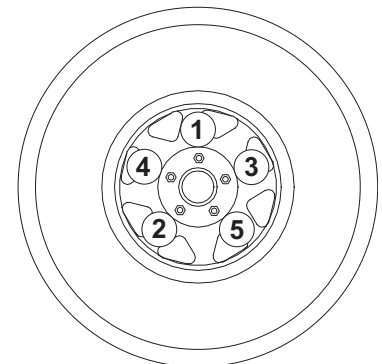

PERIODIC OR PREVENTIVE MAINTENANCE

The periodic maintenance schedule below lists basic maintenance intervals for the engine. For detailed maintenance procedures refer to the Engine Operator's Manual. A copy of this manual was supplied with the unit when it was shipped from the factory. For additional or replacement copies of the Engine Operator's Manual, contact an authorized engine dealer in your area.

	Check Daily	Every 50 Hours	Every 250 Hours	Every 500 Hours	Every 1000 Hours	Every 2 Years
Lubricate Mast Cables			■***			
Check Tire Pressures	■					
Check Engine Oil Level	■					
Check Engine Coolant Level	■					
Check Fuel Level	■					
Check Alternator Belt	■					
Drain Fuel Filter		■*				
Check Radiator Hoses		■				
Change Engine Oil & Filter		■**	■			
Check All Electrical Connections			■			
Check For Fuel Leaks			■			
Replace Fuel Filter Element			■			
Inspect and Clean Radiator Fins				■		
Lubricate Leveling Jacks				■		
Clean Air Filter Element, replace if necessary				■		
Replace Alternator Belt				■		
Inspect Engine Starting Battery					■	
Check Valve Clearance						■
Drain and Clean Fuel Tank						■
Change Engine Coolant						■
Replace Radiator Hoses						■

*Drain daily in humid or rainy conditions.

**Change the engine oil and filter after the first 50 hours of operation, then every 250 hours.

***Lubricate the mast cables with chain and wire rope lubricant every 250 hours or any time the unit is serviced.

OPTIONAL LOWER RADIATOR HOSE HEATER USE AND MAINTENANCE

The following points should be followed when operating a unit equipped with a lower radiator hose heater.

▲ WARNING

Improper use of the lower radiator hose heater could result in serious personal injury.

- Ensure cooling system is full of proper mixture of water and engine coolant before each heater use.
- Heater is designed for all-night operation; however, 2-5 hours of heating just prior to starting is usually sufficient for proper engine starting.
- When heater is in operation, unit must be parked in a level position to maintain the proper orientation of the heater.
- Use only an undamaged extension cord, outdoors rated, three-prong grounded 120VAC cord with a minimum amperage rating of 10A. Connect to properly grounded 120VAC, GFCI outlet only.
- Unplug extension cord from power first; then unplug heater cordset from extension cord before starting the engine.

TROUBLESHOOTING THE LIGHTS

▲ WARNING

HIGH VOLTAGE! THIS UNIT USES HIGH VOLTAGE CIRCUITS CAPABLE OF CAUSING SERIOUS INJURY OR DEATH. ONLY A QUALIFIED ELECTRICIAN SHOULD TROUBLESHOOT OR REPAIR ELECTRICAL PROBLEMS OCCURRING IN THIS EQUIPMENT.

MAST LIGHTS OFF BUT BALLAST INDICATORS ON CONTROL PANEL ARE ON:

1. Mast light is too hot. Allow light to cool 10-15 minutes before restarting.
2. Faulty bulb connection. Check that the bulb is tight in the socket.
3. Bulb broken. Check for broken arc tube or outer bulb jacket, broken or loose components in bulb envelope or blackening/deposits inside tube.
4. Check the connections inside the mast junction box and each mast light housing/socket.
5. Check the mast electrical cord for damage and check the cord connections inside the control box.

MAST LIGHTS OFF AND BALLAST INDICATORS ON CONTROL PANEL ARE OFF:

1. Check the connections inside the control box and inside each ballast box.
2. Generator output incorrect. Check the incoming voltage to the ballast by checking the available voltage on the duplex receptacle. Incoming voltage should be 120V +/- 5V. If voltage is incorrect engine speed may need to be adjusted or generator may require service. Contact GODWIN PUMPS OF AMERICA Technical Service Department for more information.
3. Low transformer output. The voltage from the transformer should read approximately 400 VAC as the light "strikes" (induces an arc), then drop and slowly rise back up to stabilize at 240-260 VAC. On quick disconnect models, measure across the junction box terminals when the light is unplugged. On hard wired models, remove the mast junction box cover and insert the wire probes into the connector blocks for the lights and ground. If proper voltage is not achieved, perform capacitor check to determine if the capacitor or coil needs to be replaced.

MAST LIGHTS ON BUT THE LIGHT OUTPUT IS LOW:

1. Fixture or lens dirty. Clean reflective surface inside fixture and both inside and outside surface of glass lens.
2. Bulb worn. Replace bulb due to normal use.
3. Check the mast coil cord, mast junction box and mast light connections.
4. Generator output incorrect. Check the incoming voltage to the ballast. Incoming voltage should be 120V +/- 5V. If voltage is incorrect engine speed may need to be adjusted or generator may require service.
5. Low transformer output. Perform transformer check as described above.

If problems persist, contact GODWIN PUMPS OF AMERICA Technical Service for assistance.

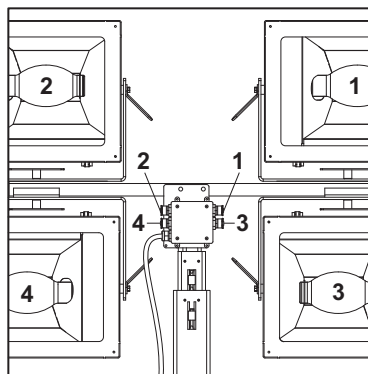

MAST LIGHT CONNECTIONS

AC WIRING DIAGRAM - GLT416

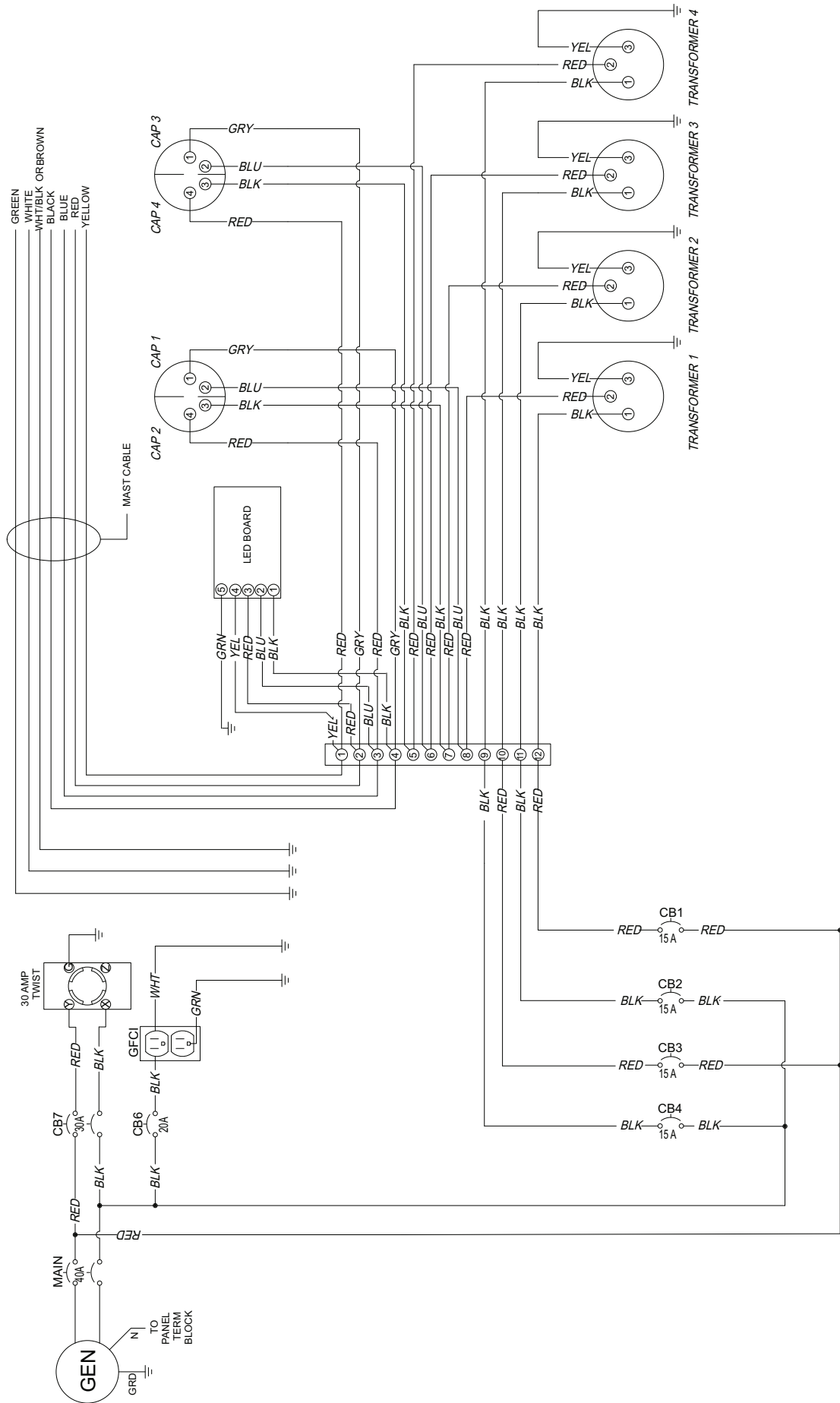

AC WIRING DIAGRAM - GLT418

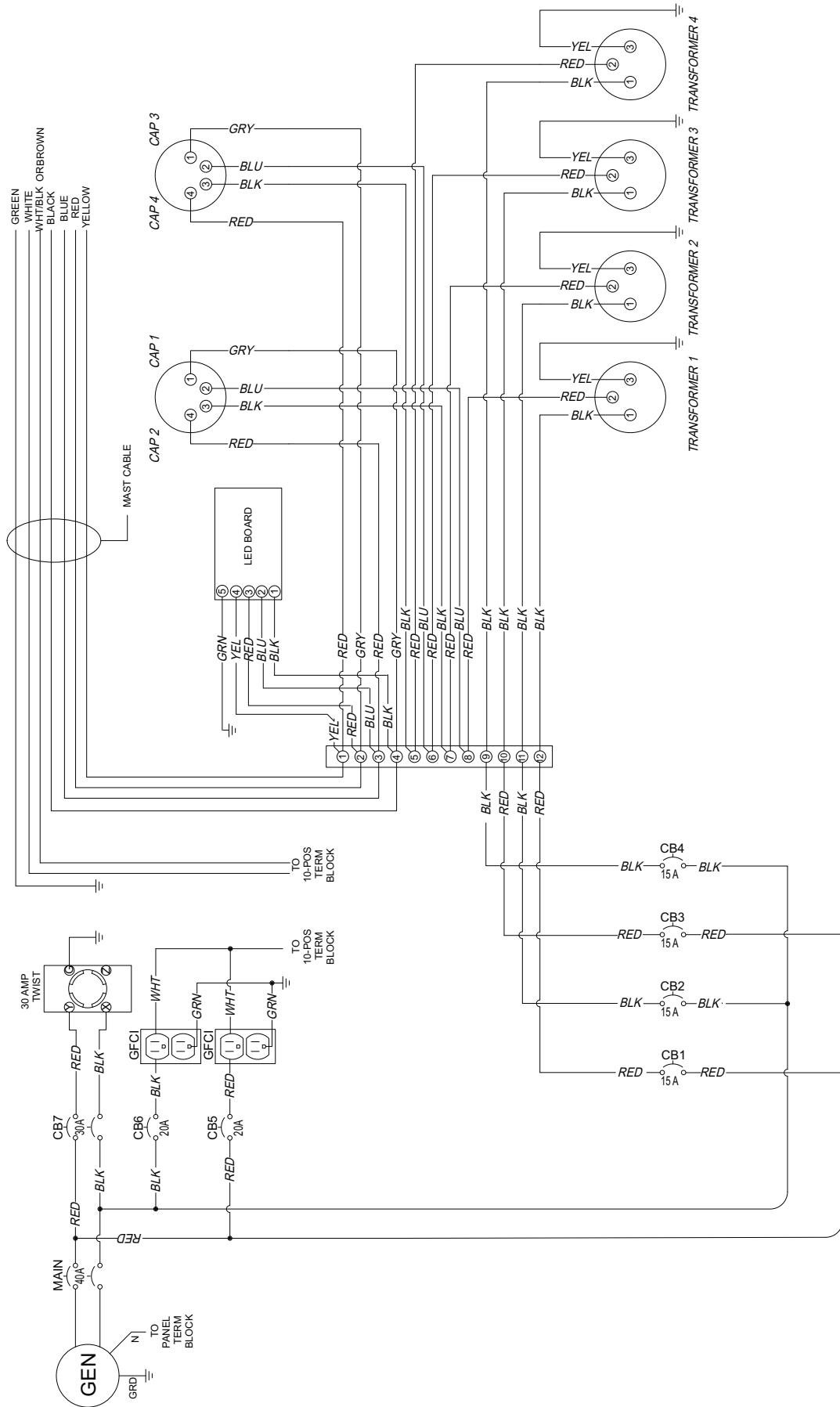

DC WIRING DIAGRAM - KUBOTA

After serial Number: 0900090

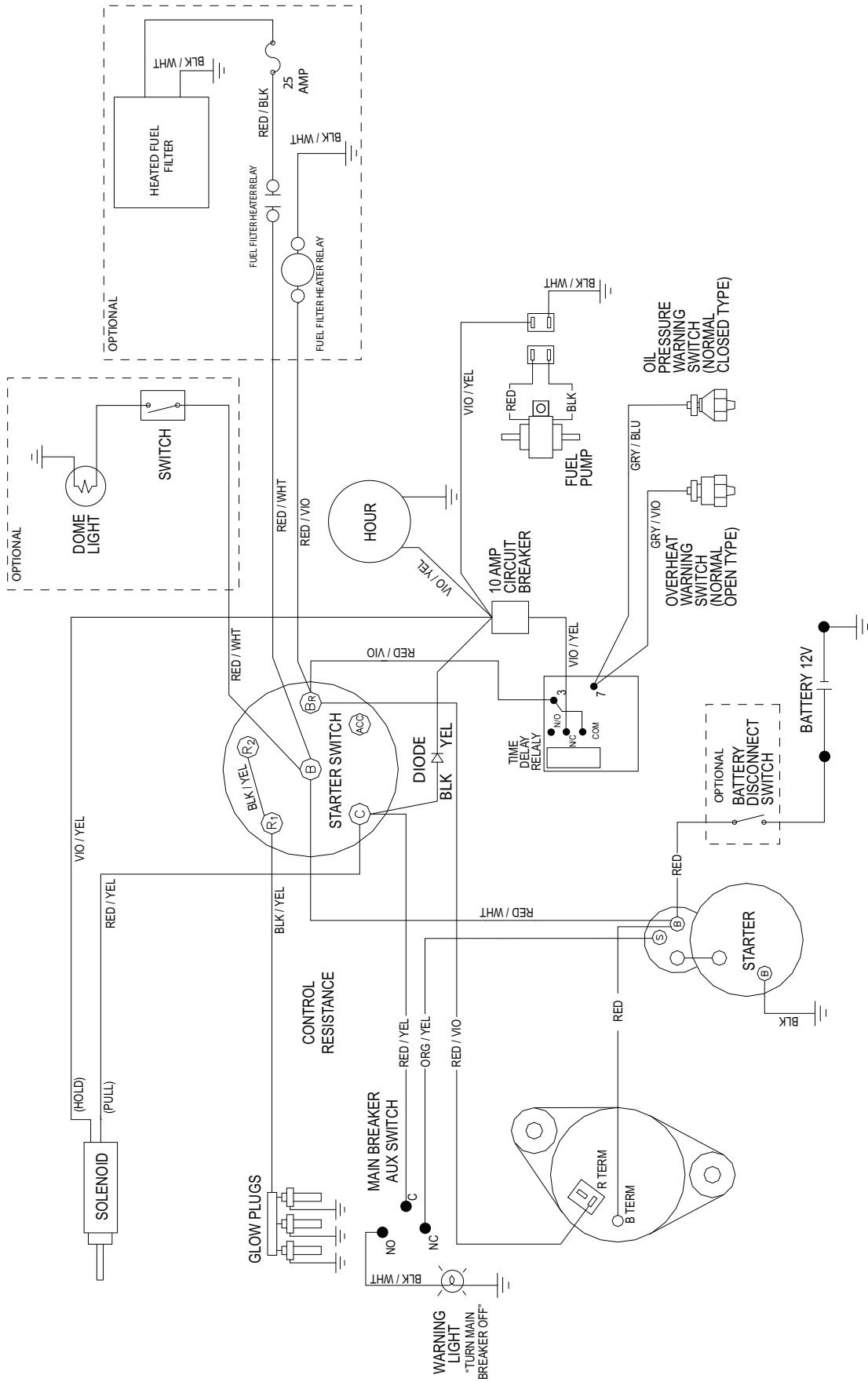

DC CIRCUIT WIRING DIAGRAM - DUAL ELECTRIC WINCH

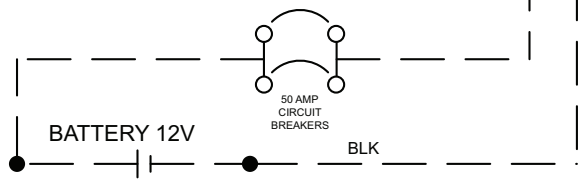
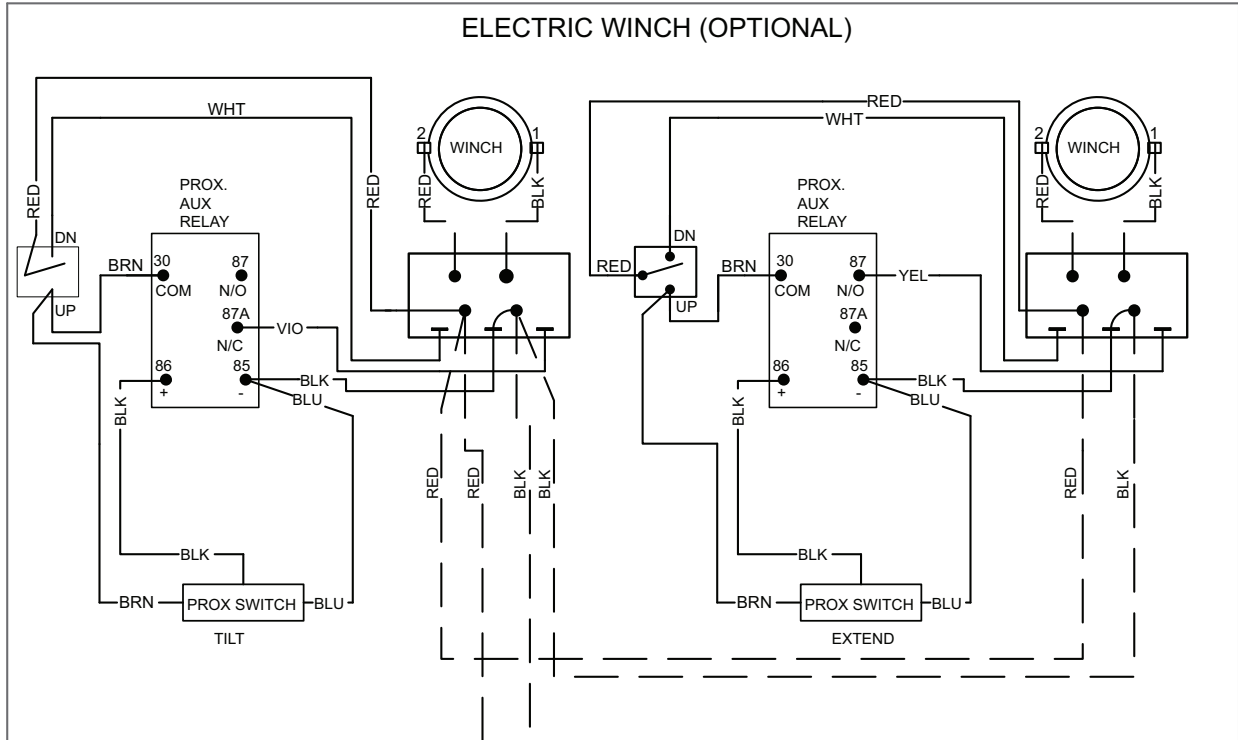

MAST JUNCTION BOX WIRING

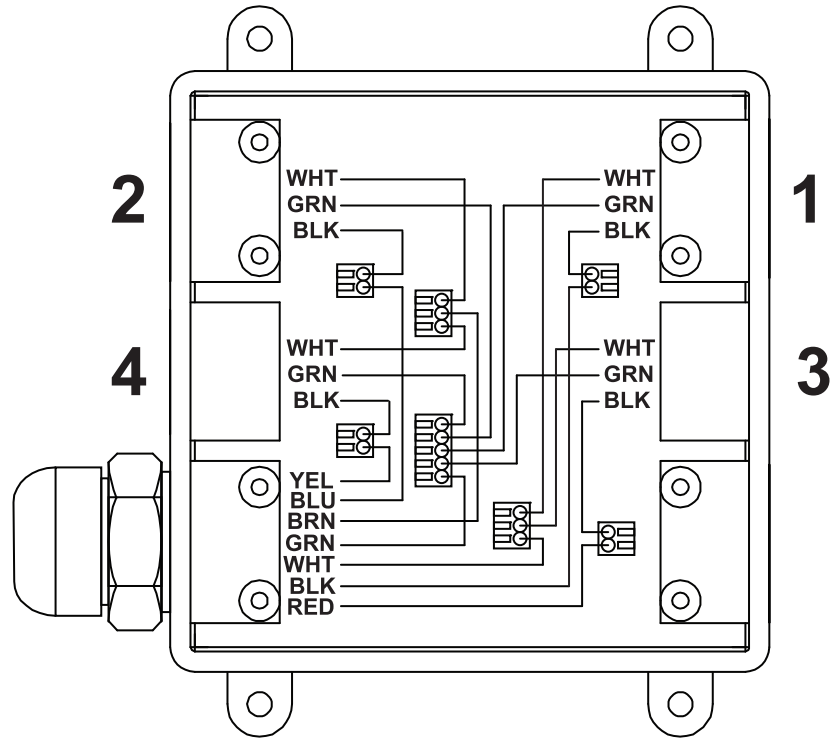

REV: B
PART NO: HUSH-10714
06.14.10